

Application Methods for Avery Dennison® self-adhesive films

issued: 02/2015

Avery Dennison® self-adhesive films are available in a wide range of qualities for many different applications. Application of these films has to be done in the best possible manner: this will ensure the product will perform as expected. Successful application results in an adequate bond between adhesive and the substrate. Please read the instructions for substrate preparations first before application of decals.

Substrate preparation:

A substrate has to be cleaned by:

1. Washing with a mild detergent solution, after which the surface should be rinsed and dried with a lint free cloth.
2. Wiping with a solvent-saturated cloth, until all dirt and/or grease has been removed. The solvent should be sufficiently mild not to attack the substrate (e.g. methylated spirits).

Many commercially available cleaning/degreasing products exist: the applicator should establish the suitability of a product prior to actual use. In addition, the following factors should be considered prior to decal application:

- Bare metals can best be prepared for decal application by cleaning with a detergent solution, followed by solvent cleaning with a (solvent) saturated cloth. Solvents that can be used include: white spirit, heptane or other suitable degreasing solvents.
- Car wax and polish residues must be completely removed.
- Paint surfaces must be completely dry and hardened. On most baked paints; decals can be applied immediately after cooling down. Air dried paints and car repair paint require at least week to dry out before decals are applied. Solvent residues in painted substrates which are not completely dry may adversely affect decal adhesion, and can cause excessive shrinkage or blistering.
- Painted substrates which will act as a substrate for self-adhesive decals should be applied according to the paint manufacturer's instruction. Here too it is important to avoid solvent retention. Paint system components that are not compatible or that do not adhere properly to each other may cause paint to be lifted when decals have to be removed after use.

Self-adhesive films have various degrees of flexibility/conformability. On three dimensionally shaped surfaces a cast film generally gives the best results. The use a hairdryer will improve the conformability and reduce the tendency for films to delaminate or lift. Always respect the minimum application temperatures as given in the technical datasheets.

TECHNICAL BULLETIN 1.4

Small size decals

Place the decal upside down on a flat surface. Remove the liner along one edge for 2-3 cm and fold it backwards as shown in the drawing. The result is an edge of 2-3 cm exposed adhesive.

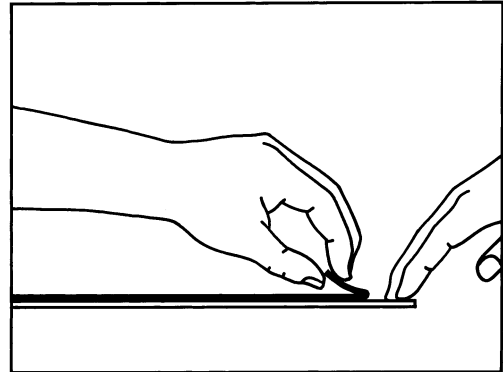

Position the decal that is still covered with liner on the application surface. Once it is in the right position, the exposed edge is pressed to the surface, starting at the middle of the edge, working your way up and down. Do not allow pleats or bubbles to be formed.

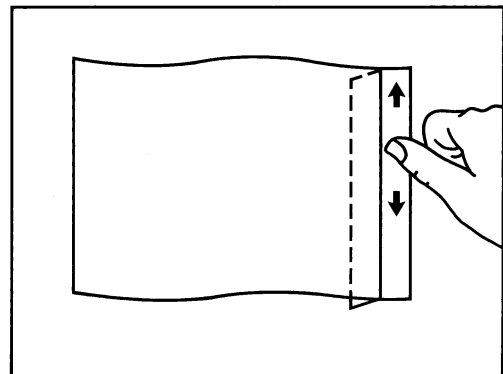

Lift the decal a bit and remove the liner over 15-20 cm (or more if you feel experienced enough) distance. Keep the decal close to the application surface and start to apply it with overlapping squeegee strokes, beginning at the middle of the already applied edge. Proceed with this application until the entire decal is applied.

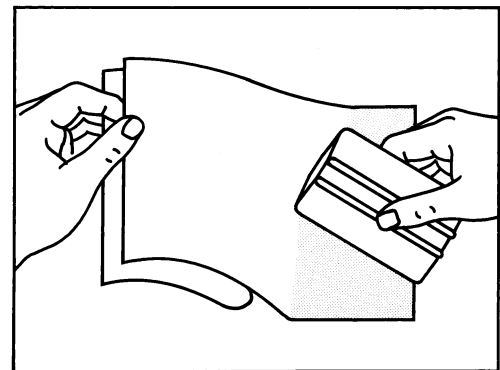

Check if all edges have been applied properly and re-squeegee them if necessary. Bubbles can be punched with a needle and the air can be removed by pushing it through the hole, starting at the edges of the bubble.

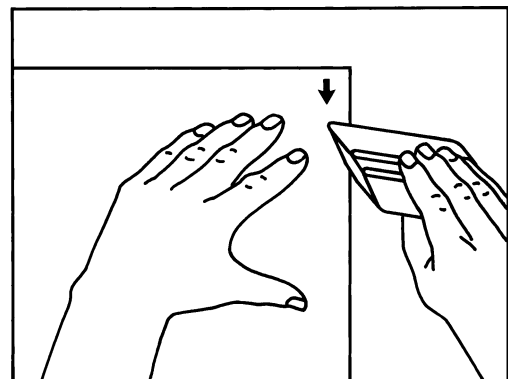

TECHNICAL BULLETIN 1.4

Medium size decals

Apply reference marks on the application surface so that the position of the decal to be applied can easily be identified. Masking tape or easily erasable markers will generally do this job.

Place the decal upside down on a flat surface. Remove the liner along one edge for 2-3 cm and fold it backwards as shown in the drawing. The result is an edge of 2-3 cm exposed adhesive.

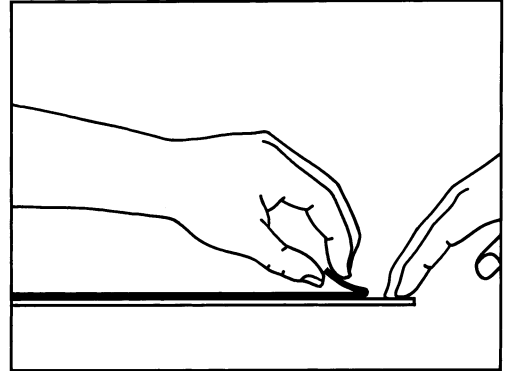

Take the decal up close to the exposed edge and position the decal on the application surface, making sure it lines up with the reference marks.

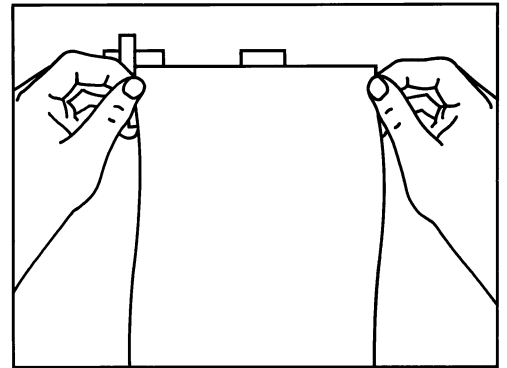

Then the exposed edge is pressed to the surface, starting at the middle of the edge working your way up and down (or left to right (as shown on this picture)). Do not allow pleats or bubbles to be formed.

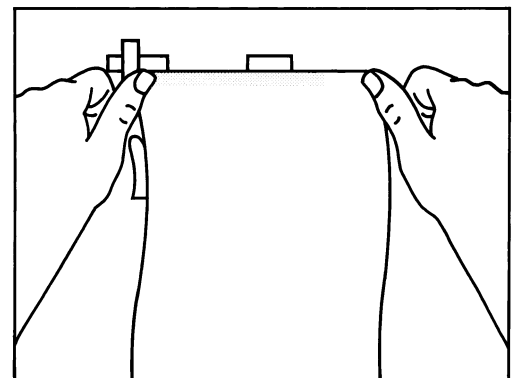

TECHNICAL BULLETIN 1.4

Lift the decal a bit and remove the liner over 15-20 cm (or more, if you feel experienced enough) distance. Keep the decal close to the application surface and start to apply it with overlapping squeegee strokes, beginning at the middle of the already applied edge. Proceed with this application until the entire decal is applied.

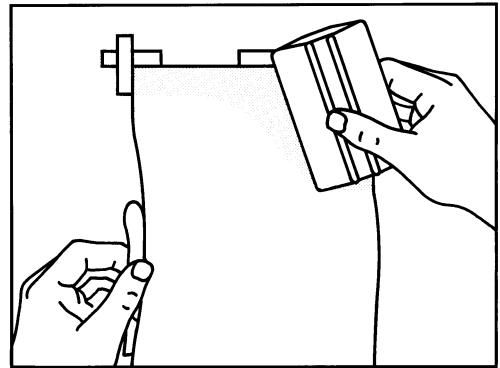

Check if all edges have been applied properly and re-squeegee them if necessary. Bubbles can be punched with a needle and the air can be removed by pushing it through the hole, starting at the edges of the bubble.

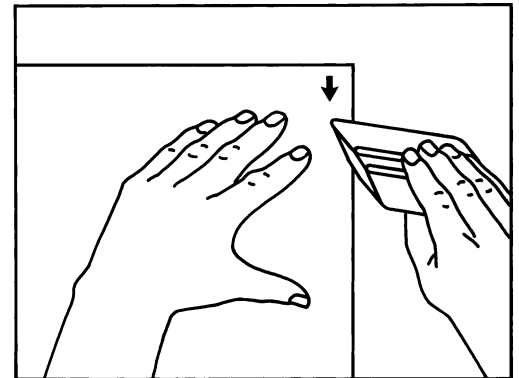

Large size decals

Position the decal, which liner is still present, to the application surface and fix it on the top edge with small strips of masking tape. Make sure that indeed the position is correct.

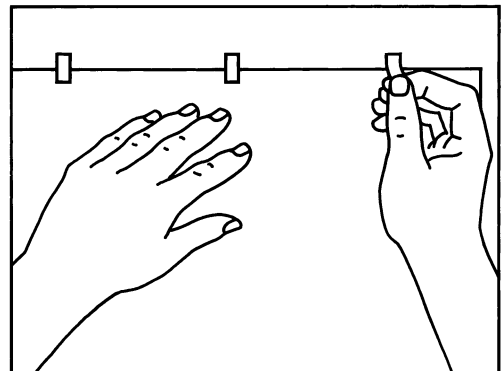

Apply a strip of masking tape over the full length of the edge, either on the right or on the left side of the decal. This strip should hold the decal in the correct position if the positioning masking tape strips are removed. If necessary, apply an extra strip of masking tape, overlapping the first one for some 50 %.

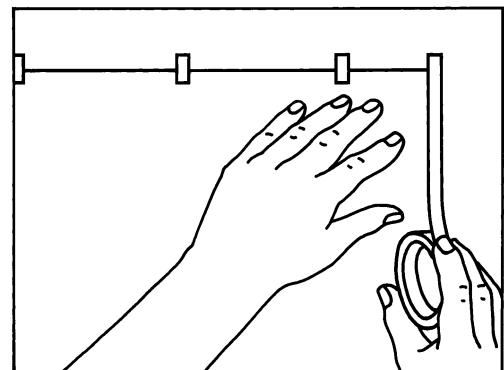

TECHNICAL BULLETIN 1.4

Remove the positioning strips from the top edge. Flip the decal over at the now formed hinge, and remove the liner over a 20-30 cm wide area parallel to the hinge. Fold the liner slightly so that the adhesive remains exposed.

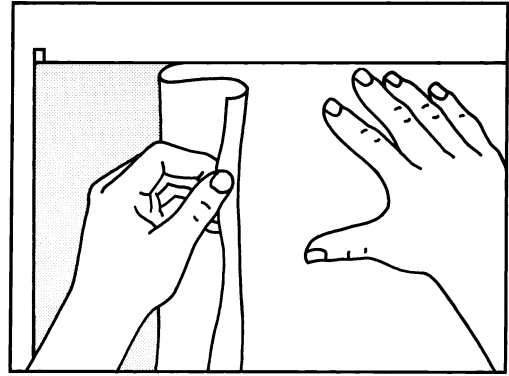

Flip the decal over and start to apply it at the hinge, making use of a hard plastic squeegee. Apply with overlapping squeegee strokes, from the middle of the hinge to the top and bottom decal edges.

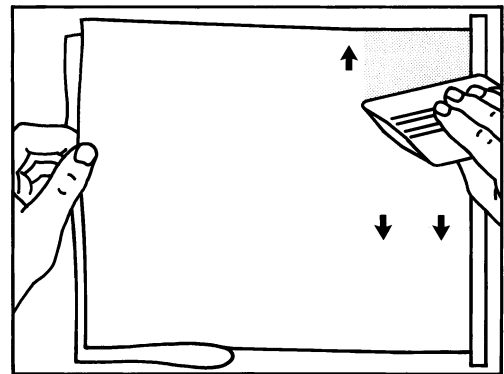

Proceed with application step by step, removing liner and applying the decal alternatively until the entire decal has been applied. Then remove the hinge and check and resqueegee all decal edges.

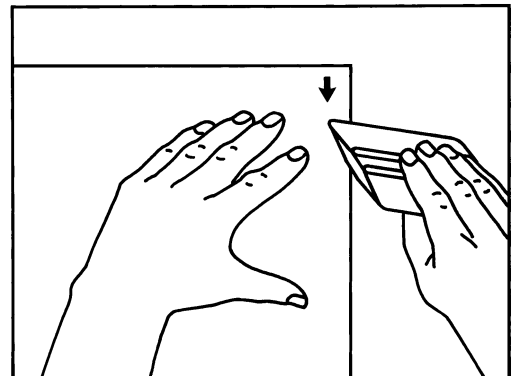

TECHNICAL BULLETIN 1.4

Application of plotter cut texts and logos

Texts and logos that are cut on a plotter or by kiss die cutting should always be applied with the help of application tape. Application tape is laminated over the graphics and serves as a means of transport and it keeps the graphic in the right shape during the application. Generally, the application method for these graphics do not differ very much of the one for printed graphics. Depending on the size of the graphic, one can make use of a hinge.

Fix the entire graphic, including liner and application tape, with strips of masking tape in the correct position and apply a horizontal or vertical hinge.

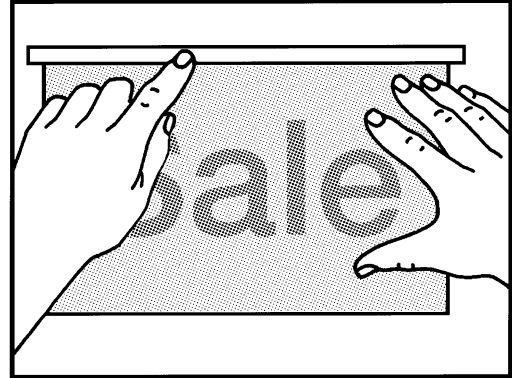

Flip the graphic back on the hinge and remove the liner partially, or if size allows entirely. Prevent the graphic to stick prior to application.

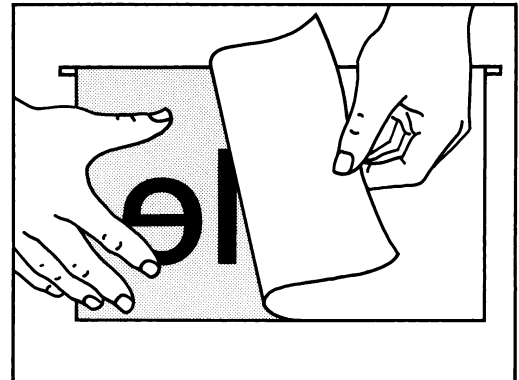

Without touching the adhesive of the graphic, apply it to the surface with a hard plastic squeegee with overlapping strokes. Proceed with application from the hinge to the other end of the decal.

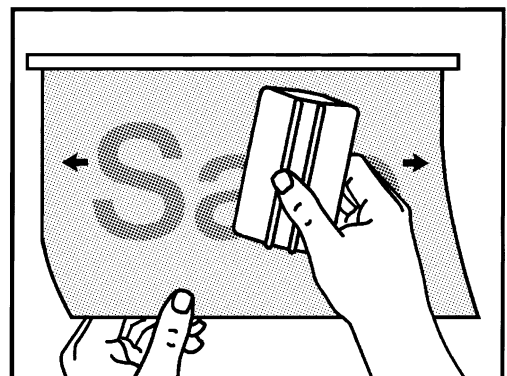

TECHNICAL BULLETIN 1.4

Remove the application tape at an angle of close to 180°. Preferably this should be done a few minutes. After the graphic has been applied as this may prevent air bubbles to appear. Check and resqueegee all edges of the graphic.

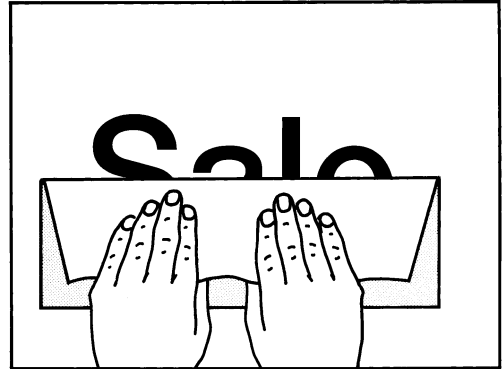

Application to riveted surfaces.

Only use cast films riveted surfaces. Printed or cut graphics made of cast films should always be applied with application tape overlaminated. This will keep the graphic in the right size as cast films are conformable and hence, easy to stretch.

Fix the emblem in the correct position by means of a masking tape hinge: the decals edge should not cross a rivet. See also instructions above.

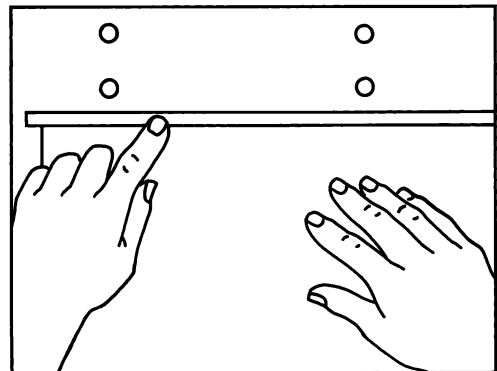

Flip the decal over the hinge and partially remove some liner, beginning at the hinge. Do not remove all liner to prevent pre-sticking.

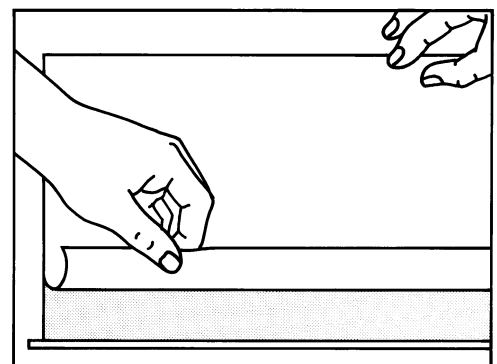

TECHNICAL BULLETIN 1.4

As with large decals, start application from the hinge towards the lower edge of the decal, whereby it is important to work from the centre to the edges. When you reach a rivet, push the film towards the rivet head with the squeegee and apply the decal leaving an air “bubble” around the rivet. Maintain sufficient tension in the decal to prevent pleats around the rivets.

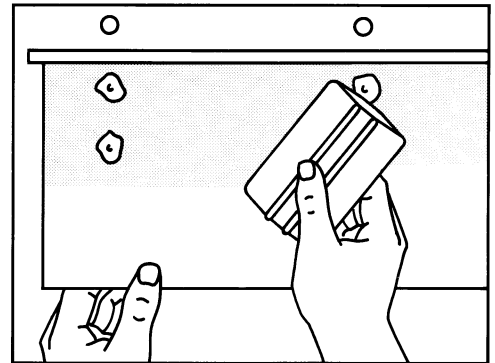

Once the entire decal has been applied and with the application tape still in place, punch with a needle some 4-5 holes around the rivet and proceed to apply the film with a squeegee. Once finished, remove all application tape.

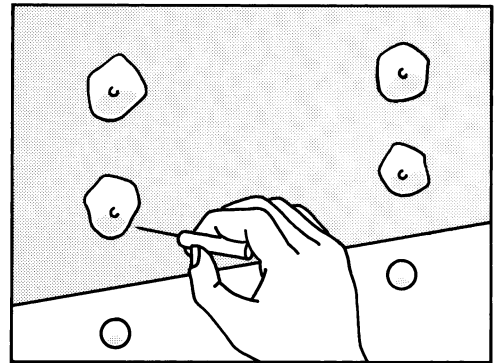

Push as much air out as possible and heat the film around each individual rivet with a hairdryer until the film softens. (Do not overheat !!). Push the film down with a squeegee or with your thumb for as close as possible to the rivet edge.

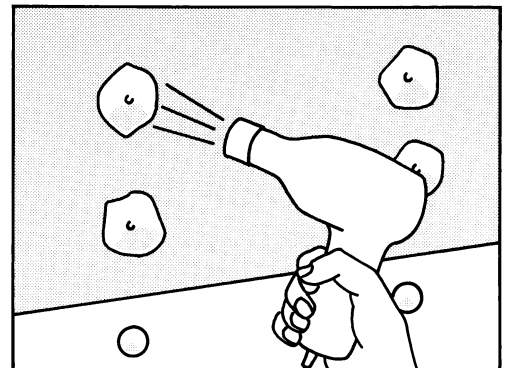

Then “mould” the film around the rivet head by means of a brush, using circular strokes. This will fix the film to the rivet edges. Application can be completed with a hard squeegee. After application, check and resqueegee all edges of the graphic applied.

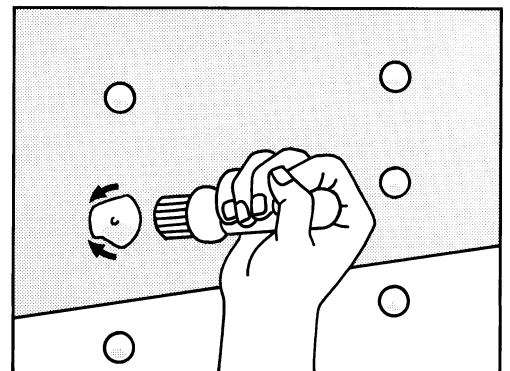

TECHNICAL BULLETIN 1.4

Application to corrugated surfaces

Position the decal to the application surface with a masking tape that can serve as a hinge. (see also previous instructions). Ensure that the hinge is in a flat section of the surface. Only remove a small area of liner to prevent pre-sticking.

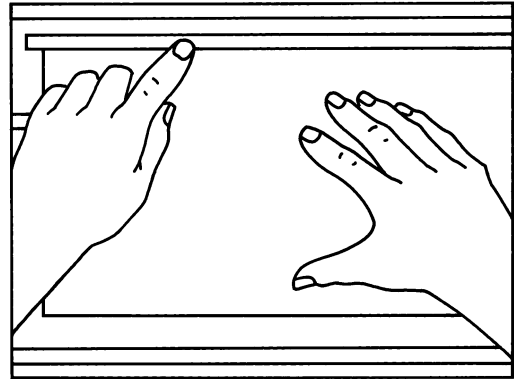

Application to this type of surface has to be done systematically: section by section should be covered with film as shown on the picture. Deviation from this application sequence may result in pleats that are impossible or difficult to get rid of.

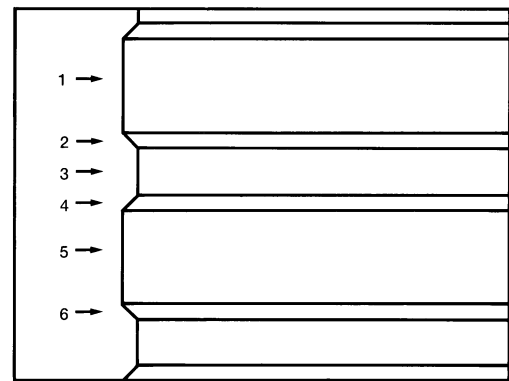

As with large size decals, start the application at the hinge (but section by section !), and apply the film from the centre to the graphics edges. This will limit the occurrence of pleats.

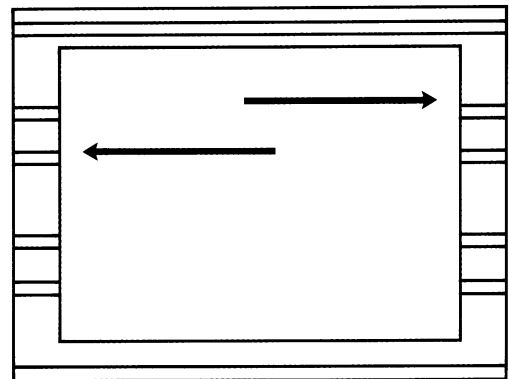

TECHNICAL BULLETIN 1.4

While keeping the adhesive free from the substrate, apply the decal with a hard plastic squeegee. Do NOT stretch the film but “follow” the surface irregularities. Stretching the film may result in delamination.

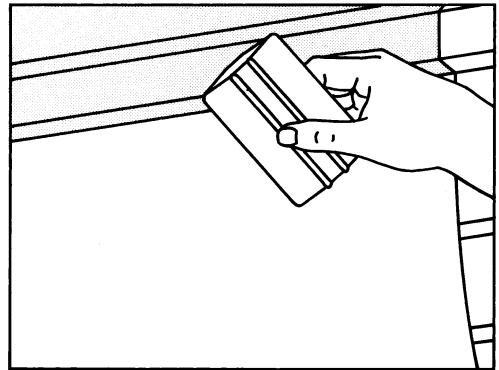

Try as much as possible to use the full width of the squeegee to press the film down over the entire surface area to be applied. Vertical sections to be applied by vertical squeegee strokes.

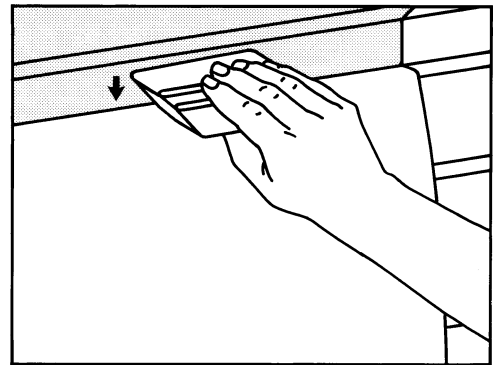

Make sure the film is applied well in the edges that border the individual sections. Remove application tape after some minutes and check and resqueegee the edges.

